

REF. NO.	LOCATION	TYPE	REGISTER NO.	REGISTER SIZE	REGISTER LENGTH	REGISTER WIDTH	REGISTER HEIGHT	REGISTER AREA	REGISTER PERIMETER	REGISTER WEIGHT
1

REF. NO.	SIZE	AR QTY	TYPE	FINISH COLOR
...

REF. NO.	SIZE	AR QTY	TYPE	FINISH COLOR
...

REF. NO.	SIZE	AR QTY	TYPE	FINISH COLOR
...

REF. NO.	SIZE	AR QTY	TYPE	FINISH COLOR
...

REF. NO.	SIZE	AR QTY	TYPE	FINISH COLOR
...

REF. NO.	SIZE	AR QTY	TYPE	FINISH COLOR
...

REF. NO.	SIZE	AR QTY	TYPE	FINISH COLOR
...

REF. NO.	LOCATION	TYPE	REGISTER NO.	REGISTER SIZE	REGISTER LENGTH	REGISTER WIDTH	REGISTER HEIGHT	REGISTER AREA	REGISTER PERIMETER	REGISTER WEIGHT
...

REF. NO.	SIZE	AR QTY	TYPE	FINISH COLOR
...

REF. NO.	SIZE	AR QTY	TYPE	FINISH COLOR
...

REF. NO.	SIZE	AR QTY	TYPE	FINISH COLOR
...

REF. NO.	LOCATION	TYPE	REGISTER NO.	REGISTER SIZE	REGISTER LENGTH	REGISTER WIDTH	REGISTER HEIGHT	REGISTER AREA	REGISTER PERIMETER	REGISTER WEIGHT
...

REF. NO.	SIZE	AR QTY	TYPE	FINISH COLOR
...

REF. NO.	SIZE	AR QTY	TYPE	FINISH COLOR
...

REF. NO.	SIZE	AR QTY	TYPE	FINISH COLOR
...

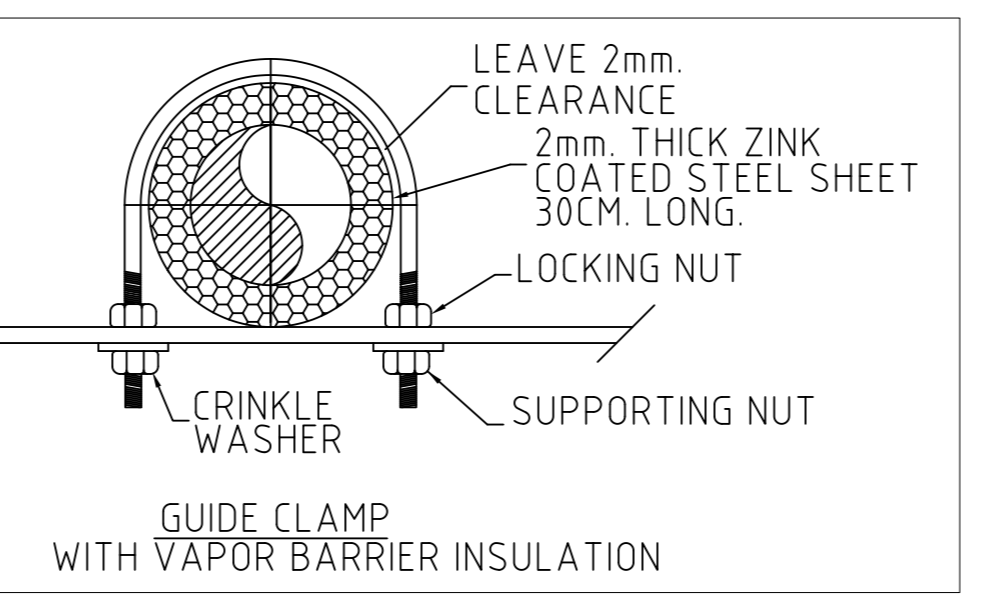
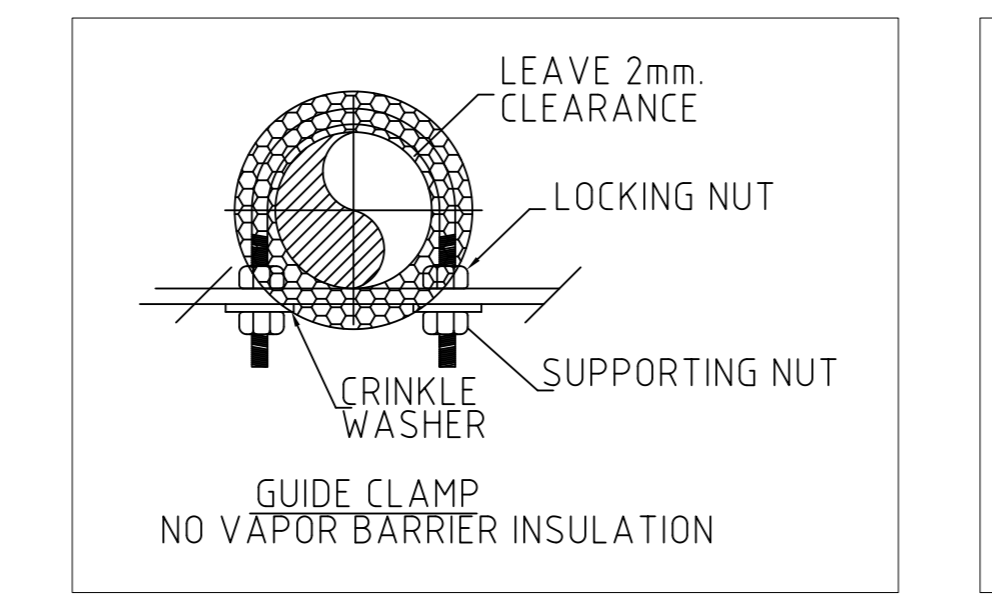
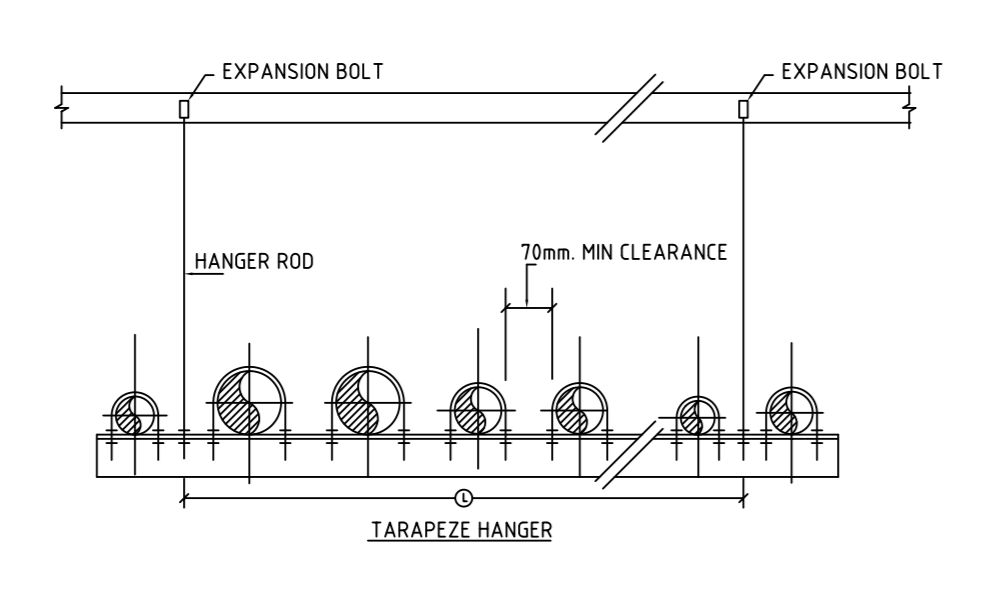
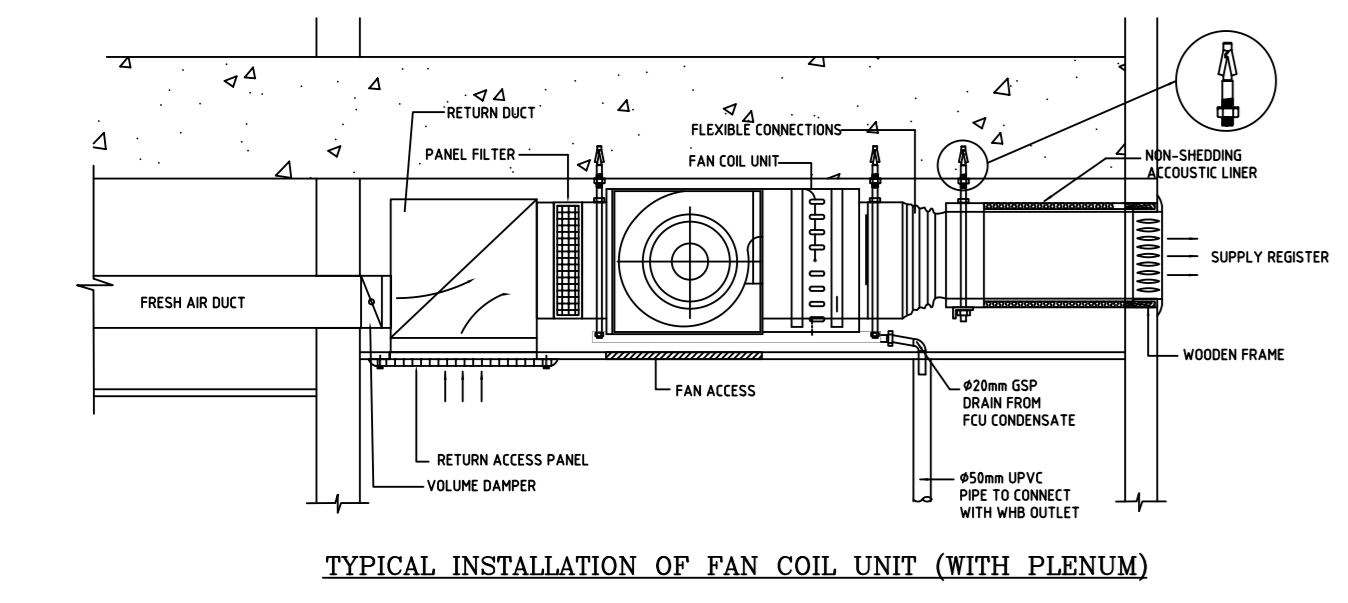

	FLEXIBLE CONNECTION 200
	VOLUME CONTROL DUMPER
	SUPPLY DIFFUSER
	RETURN DIFFUSER
	EXHAUST GRILL
	LINEAR SLOT DIFFUSER SUPPLY & RETURN
	SUPPLY GRILL
	RETURN GRILL
	DUCT RISER
	OUTDOOR UNIT

FAD	FRESH AIR DUCT
EAD	EXHAUST AIR DUCT
AHU	AIR HANDLING UNIT
FCU	FAN COIL UNIT
VD	VOLUME DUMPER
CHWS	CHILLED WATER SUPPLY
CHWR	CHILLED WATER RETURN
RLD	RETURN LINEAR DIFFUSOR
SLD	SUPPLY LINEAR DIFFUSOR
DLN	DUCT LINEAR DIFFUSOR
IL	INVERT LEVEL
LEN	LENGTH
ID	INDOOR UNIT
EG	EXHAUST GRILL
EF	EXHAUST FAN
H / L	HIGH LEVEL
F / A	FROM ABOVE
T / B	TO BELOW
D / D	DROP DOWN
SG	SUPPLY GRILL
RG	RETURN GRILL

SUB CONTRACTOR:
 T & C QATAR L.L.C. - C.R. 35109
 P.O. Box: 2329 DOHA, QATAR
 TEL: (+974) 4421 833 / 4930 614
 FAX: (+974) 4410 553 / 4930 614



CONSULTANT:
 المكتب العربي للمهندسين
 ARAB ENGINEERING BUREAU
 Telephone: +974 4477 989 Fax: +974 4477 888 P.O. Box: 148 Doha Qatar
 Email: ab@ab-qatar.com Web: www.ab-qatar.com



DESIGNER:
 GHD
 GHD
 PO Box 44352 Doha Qatar
 T: +974 4222379 F: +974 4446127
 E: dhammad@ghd.com.au www.ghd.com.au



MAIN CONTRACTOR:
 AL MADAR CONTRACTING
 P.O. Box: 2329 DOHA, QATAR
 TEL: (+974) 4675405 - 4674466
 FAX: (+974) 4671333 - C.R.: 15061
 WEB SITE: www.almadar-group.com
 Email: conteng@almadar-group.com



OWNER:
 ALI ABDUL REDA MASHHADI

PROJECT:
 AL NOOR OFFICE TOWER AT NEW DOHA
 2B+G+F+22 FLOORS

DRAWING TITLE:
 FIRST FLOOR
 HVAC + CHILLED WATER

DRAWING REFERENCE:
 75-10288-M130 - FIRST FLOOR HVAC
 75-10288-M200 - FIRST FLOOR CHILLED WATER
 75-10288-M000 - HVAC AND CHILLED WATER LEGEND
 75-10288-M170 - HVAC AND CHILLED WATER RISER DIAGRAM
 75-10288-M180 - HVAC EQUIPMENT SCHEDULES

DRAWN BY: L. MARRACINO

CHECKED BY: M. ALAA

APPROVED BY: M. MOHAMUD

DATE: 04.07.07

SCALE: 1:100 SIZE: A0

REVISION: 0

DATE: 04.07.07

DRAWING NO.: TC01M3F01067
 SHEET: 1 OF 2